

ABB MEASUREMENT & ANALYTICS | DATA SHEET

JDF200 Field Indicator



Measurement made easy

Engineered solutions for all applications

Digital LCD

- provides reliable and clear indications

Flexible configuration facilities

- provided locally via local LCD keypad, with 1 or 2 lines numeric indication and “Easy setup” menu

Signal characterization

- improves local indication by selectable transfer function

Rugged, compact, lightweight, enclosure to IP67 and Nema 4x

- enables installation in industrial environments

High reliability

- redundant acquisition system ensures enhanced dependability

Comprehensive certification approvals

- give extended applicability in plant hazardous areas

Compatible with all 4 to 20 mA, 2-wire systems

Product in compliance with Directive 2011/65/UE (RoHS II)

Field indication as you need

Model JDF field indicator provides simple and low cost remote indication of a process variable on an easy to read meter, ensuring the most useful display for any specific application.

A reliable measurement is implemented by a redundant acquisition chain and by a diagnostic process that guarantee always the correct output value.

In addition to parallel wiring to the transmitter, JDF200 allows series mode wiring, acting as junction box facility. JDF200 features a programmable signal display, providing alphanumeric plus bargraph indications:

- Two 5-digit numeric indication
- One graphic bargraph indication
- one 8-digit alphanumeric TAG indication
- a membrane keypad with 4 tactile feedback keys

The functionality as METER is achieved by the graphic bargraph which gives an analog 0-100% indication and by the 5-digit display which gives a digital indication selectable from the following options:

- 4 to 20 mA
- 0 to 100%
- engineering unit

Specification – Functional

Input range

4 to 20 mA nominal

Operating range

3.2 to 23 mA (current less than 3.2 mA will blank the display)

Maximum overload

400 mA up to 30 minutes

Maximum voltage drop

2.4 V DC @ full scale range
(5.6 V DC in case of hardware failure)

Update time

0.5 sec.

Transfer functions (input to indication)

User-selectable for indication as linear or square root, power of $3/2$ or $5/2$, horizontal or spherical tank. Predefined 22 points linearization table available on request.

Specification – Operative limits

Temperature limits °C (°F)

Ambient

The operating temperature is: -20 to 70 °C (-4 to 158 °F). Loop integrity is granted without damage to the field indicator in the range -40 to 85 °C (-40 to 185 °F), with display not clearly readable or blank.

IMPORTANT

For Hazardous Atmosphere applications see the temperature range specified on the certificate/approval relevant to the aimed type of protection.

Storage

- -40 to 85 °C (-40 to 185 °F)

...Specification – Operative limits

Environmental limits

Electromagnetic compatibility (EMC)

- Comply with EN 61326-1.
- Surge immunity level: 2 kV
(according to IEC 61000-4-5 EN 61000-4-5)

Humidity

- Relative humidity: up to 100 %
- Condensing, icing: admissible

Vibration resistance

- Accelerations up to 2 g at frequency up to 1000 Hz
(according to IEC 60068-2-6)

Shock resistance

- Acceleration: 50 g
- Duration: 11 ms
(according to IEC 60068-2-27)

Wet and dust-laden atmospheres

- The transmitter is dust and sand tight and protected against immersion effects as defined by IEC 60529 (2001) to IP 67 (IP 68 on request) or by NEMA Type 4X.

Hazardous atmospheres

Type of protection "Intrinsic safety":

ATEX Europe (code E1) approval
 II 1G Ex ia IIC Tx Ga and II 1D Ex ta IIIC Tx Da IP67 and
 II 1D Ex ia IIIC Tx Da IP67
 IECEx (code E8) approval
 Ex ia IIC Tx Ga and Ex ta IIIC Tx Da IP67 and Ex ia IIIC Tx Da IP67

Type of protection "EXPLOSION PROOF":

ATEX Europe (code E2) approval
 II 2G Ex db IIC Tx Gb and II 2D Ex tb IIIC Tx Db IP67
 IECEx (code E9) approval
 Ex db IIC Tx Gb and Ex tb IIIC Tx Db IP67

Type of protection "Type "n" and Intrinsically safe Ex ic":

ATEX Europe (code E3) type examination
 II 3G Ex nA IIC Tx Gc and II 3G Ex ic IIC Tx Gc and II 3D Ex tc IIIC Tx Dc IP67
 IECEx (code ER) type examination
 Ex nA IIC Tx Gc and Ex ic IIC Tx Gc and Ex tc IIIC Tx Dc IP67

Intertek US (code EV) and Intertek Canada (code EU):

— Explosionproof

US: Class I, Div. 2, Groups A, B, C, D T6...T4
 Class II, Div 2 Groups F, G T6...T4
 Class I, Zone 1 AEx d IIC T6...T4 Gb
 Class II, Div 1 Groups E, F, G T6...T4
 Zone 20 AEx ta IIIC T85°C...T135°C Da

Canada: Ex d IIC T6...T4 Gb
 Ex tb IIIC T85°C...T135°C Db
 Ex ta IIIC Tx Da IP67

— Non-sparking

US: Class I, Zone 2 AEx nA IIC T6...T4 Gc
 Class I, Div 2 Groups ABCD T6...T4

Canada: Ex nA IIC T6...T4 Gc

— Intrinsically safe

US: Class I, Zone 0 AEx ia IIC T6...T4 Ga
 Class I, Division 1 Group A, B, C, D T6...T4
 Class II, Division 1 Group E, F, G T6...T4
 When connected per drawing No. DH3260
 Class I, Division 2 Group A, B, C, D T6...T4
 Class I, Zone 2 AEx ic IIC T6...T4 Gc
 When connected per drawing No. DH3260

Canada: Ex ia IIC T6...T4 Ga
 Ex ia IIIC T85°C...T135°C Da
 When connected per drawing No. DH3260
 Ex ic IIC T6...T4 Gc
 When connected per drawing No. DH3260

— Enclosure type 4X

COMBINED ATEX (code EW = E1 + E2 + E3), (code E7 = E1 + E2)

COMBINED ATEX, Intertek, IECEx (code E5 = EW + EV + EU+ EI)

COMBINED Intertek Approvals US and Canada

— Intrinsically safe (code EJ)

— Explosionproof (code EK)

— Nonincendive (code EL)

COMBINED IECEx (code EH = E8 + E9), (code EI = E8 + E9 + ER)

Kosha (Korea) Intrinsic Safety, Explosion Proof

REFER TO CERTIFICATES OR OPERATING INSTRUCTIONS FOR AMBIENT TEMPERATURE RANGES (WITHIN THE LIMITS OF -50 TO 85°C) RELATED TO THE DIFFERENT TEMPERATURE CLASSES

Specification – electrical characteristics and options

Optional indicator

Integral display with integral keypad (code L1)

- Wide screen LCD, 128 x 64 pixel, 52.5 x 27.2 mm (2.06 x 1.07 in.) dot matrix. Multilanguage.
- Four keys for configuration and management of device.
- Easy setup for quick commissioning.
- User selectable application-specific visualizations.
- Display may also indicate customizable diagnostic messages and provides configuration facilities.
- The indicator is user orientable, selecting one of 4 possible positions at 90°.

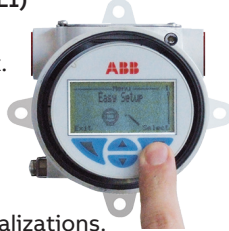

Indications

- The LCD display provides the following visualizations:
- 8-digit alphanumeric for tag, in the top line (left corner)
 - one line of 6-digit with height of 8 mm. or two lines of 8-digit with height of 5 mm., including decimal point, for numeric indication of variables, selectable between current or other 2 process values, plus relevant engineering units
 - a bargraph of 30 mm. for indication of the input current signal in percentage with 0 to 100%.Environment

Specification – Performance specifications

Stated at reference condition to IEC 60770 ambient temperature of 20 °C (68 °F), relative humidity of 65 %, atmospheric pressure of 1013 hPa (1013 mbar).

Indication accuracy

- digital: ± 0.10 % of span (16 mA) ± 1 digit.
- bargraph: ± 1 %

Resolution

16-bit conversion.

Ambient temperature effect

± 0.15 % of span (16 mA), for a temperature variation from 20 °C (68 °F) to the operating temperature limits of -20 or 70 °C (-4 or 158 °F)

Electromagnetic field

Meets all the requirements of EN 61326-1.

Specification – Physical

(Refer to ordering information sheets for variant availability)

Materials

Electronic housing and covers

Aluminium alloy (copper content ≤ 0.3 %) with baked epoxy finish (colour RAL9002); AISI 316 L ss.

Covers O-ring

Buna N.

Kit for pipe mounting

AISI 316 L ss V-bolt with nuts and washers allowing installation on vertical and horizontal 60 mm. (2in) pipe. The field indicator housing provides 4 holes in the casting allowing wall mounting by 6 mm. dia. screws (not supplied).

Plates

Identification and certification plates: self-adhesive attached to the electronics housing or AISI 316 ss fastened to the electronics housing with rivets or screws. Optional wired-on customer data plate: AISI 316 ss. Laser printing on metal or thermal printing on self-adhesive. For AISI 316 L ss housing it is mandatory to select option I2 or I3 for plates in AISI 316 ss.

Display (code Lx)

4-position (at 90°) user orientable.

Optional extras

Metal plates (code Ix)

Code I2: AISI 316 ss identification plate with laser printed tag (up to 31 characters) and scale details (up to 31 characters: lower and upper scale values and engineering unit) screwed to housing. AISI 316 ss certification plate fixed to housing by rivets.

Code I1: AISI 316 ss wired-on plate with laser printed customized data (4 lines of 32 characters with 4 mm/0.16 in. height).

Code I3 = I1 + I2.

Design and calibration certificates (codes Cx)

Tag and manual language (codes Tx and Mx)

Electrical connection plug (code Z1)

One certified stainless steel plug to match electrical connection thread

...Specification – Physical

Electrical connections

Two $\frac{1}{2}$ in. – 14 NPT or M20x1.5 threaded conduit entries, direct on housing.

Terminal block

Three terminals for signal wiring up to 2.5 mm² (14 AWG), also with connection points for test and communication purposes.

Grounding

Internal and external 6 mm² (10 AWG) ground termination points are provided.

Mounting position

Indicator can be mounted in any position.

Mass (without options)

0.9 kg approx (2 lb); add 0.1 kg (0.2 lb) for mounting kit; add 1.05 kg (2.3 lb) for AISI housing.

Packing

Carton 27 x 24 x 20 cm approx (11 x 10 x 8 in.).

Mounting dimensions

(not for construction unless certified) – dimensions in mm (inch)

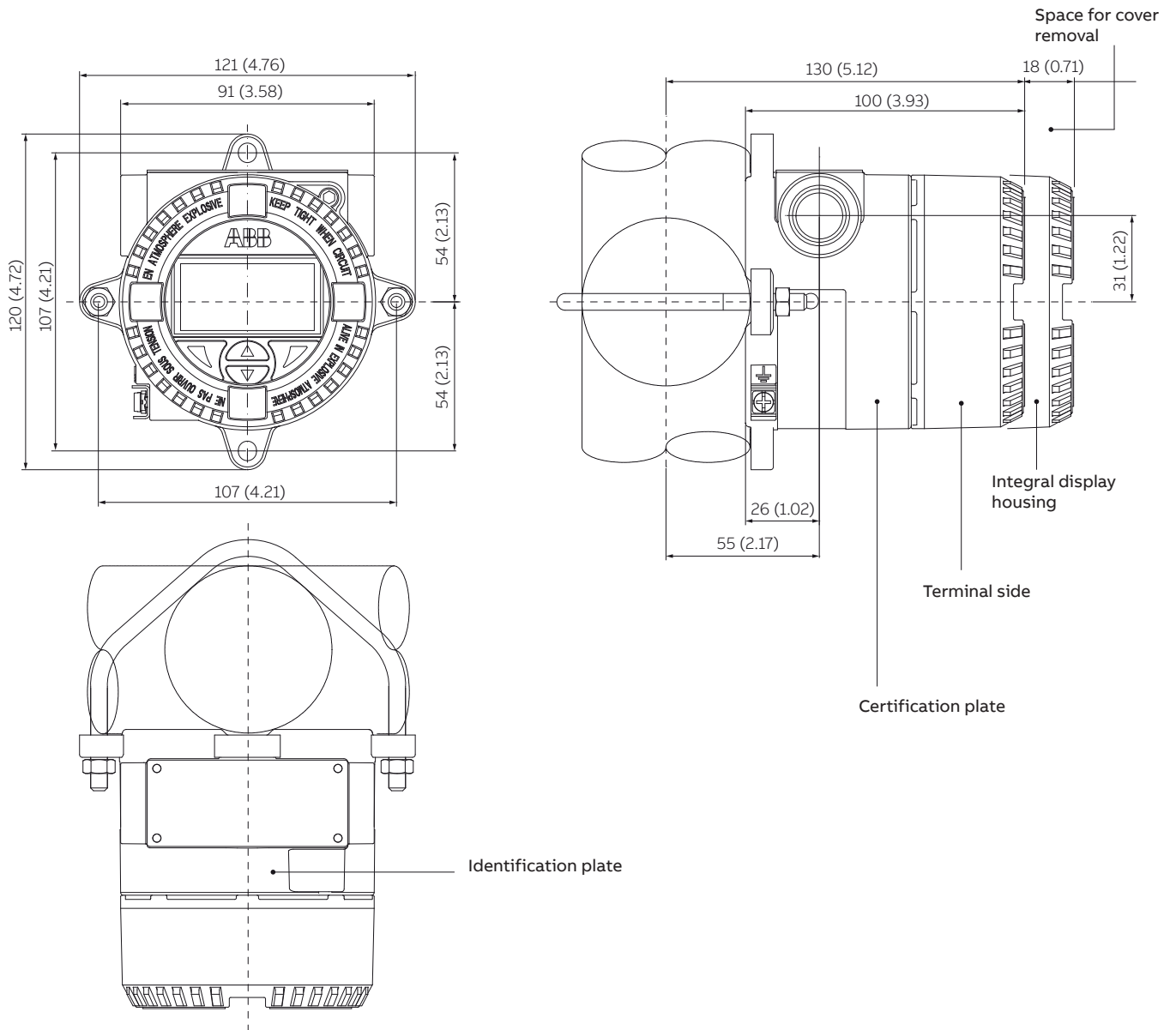
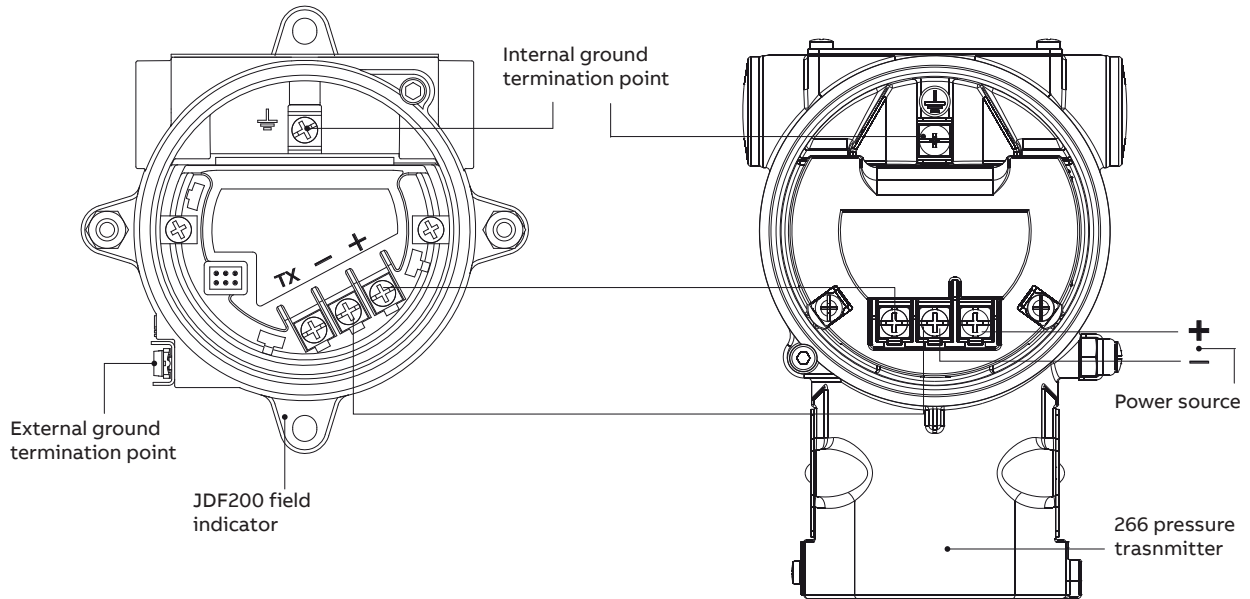

Figure 1 JDF200 dimentional drawing

...Dimensions

Wiring as remote indicator



NOTE – This wiring as remote indicator is not applicable for 266 pressure transmitter with surge protection option code S2

NOTE – JDF200 to be used as indicator with all devices ensuring minimum voltage drop on the “ext. meter” terminal

Wiring as junction box

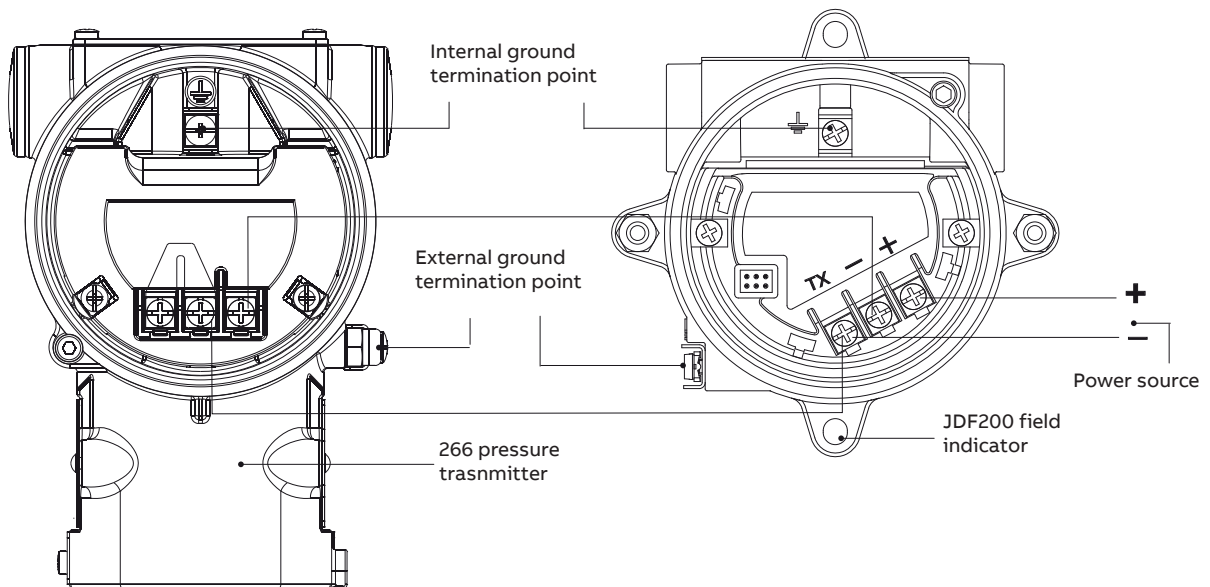

Figure 2 JDF200 Wiring drawings

Ordering Information

Basic ordering information model JDF Field Indicator

Select one character or set of characters from each category and specify complete catalog number.

Refer to additional ordering information and specify one or more codes for each instrument for required additional options.

| Base model -- 1st to 6th characters | J D F 2 0 0 | X | X |
|--|---|---|---|
| Field Indicator | | | |
| Housing material and electrical connection - 7th character | | | |
| Aluminium alloy | 1/2 in. - 14 NPT | A | |
| Aluminium alloy | M20 x 1.5 (CM 20) | B | |
| AISI 316 L ss (I2 or I3 additional code required) | 1/2 in. - 14 NPT | S | |
| AISI 316 L ss (I2 or I3 additional code required) | M20 x 1.5 (CM20) | T | |
| AISI 316 L ss painted (I2 or I3 additional code required) | 1/2 in. - 14 NPT | C | |
| AISI 316 L ss painted (I2 or I3 additional code required) | M20 x 1.5 (CM20) | D | |
| Input signal/Additional options - 8th character | | | |
| 4 to 20 mA | Options requested by "Additional ordering code" | | 7 |

...Ordering information

Additional ordering information for model JDF200

Add one or more 2–digit code(s) after the basic ordering information to select all required options.

| | XX | XX | XX |
|---|--------|----|----|
| Integral LCD | | | |
| Digital LCD integral display with integrated keypad | L1 | | |
| Hazardous area certifications | | | |
| ATEX Intrinsic Safety II 1G Ex ia IIC Tx Ga and II 1D Ex ta IIIC Tx Da IP67 and II 1D Ex ia IIIC Tx Da IP67 | | | E1 |
| ATEX Explosion Proof II 2G Ex db IIC Tx Gb and II 2D Ex tb IIIC Tx Db IP67 | | | E2 |
| ATEX No sparking and Intrinsic Safety II 3G Ex nA IIC Tx Gc and II 3G Ex ic IIC Tx Gc and II 3D Ex tc IIIC Tx Dc IP67 | | | E3 |
| Combined ATEX - Intrinsic Safety, Explosion Proof and No sparking Ex nA and Intrinsic Safety Ex ic (E1 + E2 + E3) | | | EW |
| Combined ATEX - Intrinsic Safety and Explosion Proof (E1 + E2) | | | E7 |
| Combined ATEX, IECEX, Intertek (USA) and Intertek (Canada) (PENDING) (EW + EV + EU + EI) | Note A | | E5 |
| Intertek (Canada) approval | | | EU |
| Intertek (USA) approval | Note A | | EV |
| Intertek (USA and Canada) Intrinsic Safety and Dustproof | Note A | | EJ |
| Intertek (USA and Canada) Explosion Proof | Note A | | EK |
| Intertek (USA and Canada) Nonincendive | Note A | | EL |
| IECEX Intrinsic Safety Ex ia IIC Tx Ga and Ex ta IIIC Tx Da IP67 and Ex ia IIIC Tx Da IP67 | | | E8 |
| IECEX Explosion Proof Ex db IIC Tx Gb and Ex tb IIIC Tx Db IP67 | | | E9 |
| IECEX No sparking and Intrinsic Safety Ex nA IIC Tx Gc and Ex ic IIC Tx Gc and Ex tc IIIC Tx Dc IP67 | | | ER |
| Combined IECEX - Intrinsic Safety, Explosion Proof and No sparking Ex nA and Intrinsic Safety Ex ic (E8 + E9 + ER) | | | EI |
| Combined IECEX - Intrinsic Safety and Explosion Proof (E8 + E9) | | | EH |
| Kosha (Korea) Intrinsic Safety Ex ia IIC, ExiaD 20, Ex tD A20, IP67 | | | WM |
| Kosha (Korea) Explosion Proof Ex d IIC, Ex tD A21, IP67 | | | WN |
| Combined Kosha (Korea) - Intrinsic Safety and Explosion Proof | | | WP |
| Operating manual (multiple selection allowed) | | | |
| German | | | M1 |
| Italian | | | M2 |
| Spanish | | | M3 |
| French | | | M4 |
| English | | | M5 |
| Chinese | | | M6 |

| ADDITIONAL ORDERING INFORMATION for model JDF200 | XX | XX | XX | XX | XX |
|--|----|----|----|----|----|
| Plates language | | | | | |
| German | T1 | | | | |
| Italian | T2 | | | | |
| Spanish | T3 | | | | |
| French | T4 | | | | |
| Tag plates | | | | | |
| Supplemental wired-on stainless steel plate | | I1 | | | |
| Identification and certification stainless steel plates | | I2 | | | |
| Identification, certification and supplemental wired-on stainless steel plates | | I3 | | | |
| Temperature Limit (mandatory for US Certifications) | | | | | |
| Installation to be performed down to -40 °C (-40 °F) ambient temperature | | | | NB | |
| Installation to be performed in an extended range down to -50°C (-58 °F) ambient temperature | | | | NC | |
| Certificates (multiple selection allowed) | | | | | |
| Inspection certificate EN 10204-3.1 of calibration (9-point) | | | | | C1 |
| Certificate of compliance with the order EN 10204-2.1 of instrument design | | | | | C6 |
| Electrical connection plug | | | | | |
| One certified stainless steel plug (supplied loose) | | | | | Z1 |

Note A: US Certifications require additional digit selection under “Temperature Limit” characteristic.
 For applications performed at ambient temperature range down to -50°C (option “NC”) it is mandatory to permanently protect window cover from accidental impact before installing (see specific details in the instruction manual OI/JDF200)

Standard delivery items (can be differently specified by additional ordering code)

- Self-adhesive plastic labels in English
- General purpose (no hazardous area certification)
- Kit for pipe mounting
- Operating instruction manual and labels in english (self-adhesive)
- No inspection certificate
- No electrical connection plug

ABB Ltd.**Measurement & Analytics**

Howard Road St. Neots
Cambridgeshire PE19 8EU
UK

Tel: +44 (0)1480 475321

Fax: +44 (0)1480 217948

ABB S.p.A.**Measurement & Analytics**

Via Luigi Vaccani 4
22016 Tremezzina (CO)
Italy

Tel: +39 0344 58111

ABB Inc.**Measurement & Analytics**

125 E. County Line Road
Warminster PA 18974
USA

Tel: +1 215 674 6000

Fax: +1 215 674 7183

abb.com/measurement

We reserve the right to make technical changes or modify the contents of this document without prior notice. With regard to purchase orders, the agreed particulars shall prevail. ABB does not accept any responsibility whatsoever for potential errors or possible lack of information in this document.

We reserve all rights in this document and in the subject matter and illustrations contained therein. Any reproduction, disclosure to third parties or utilization of its contents – in whole or in parts – is forbidden without prior written consent of ABB.